



August 2015

Super ThoriX + ThoriX 190

Manual

Construction

Operation

Maintenance

Intro	Page 1
Assembly Instruction Engine	Page 2
Assembly Instruction Engine	Page 3
Gas and Oil	Page 4
Carburettor	Page 5
Carburettor	Page 6
Start the Engine	Page 7
Pilotsuspension and Harness	Page 8
Pilotsuspension and Harness	Page 9
Pilotsuspension and Harness	Page 10
Pilotsuspension and Harness	Page 11
Pilotsuspension and Harness	Page 12
Altinator	Page 12.1
Throttle lever	Page 13
Pre Flight Check	Page 14
Pre Flight Check	Page 15
Powerfly Carabiner	Page 16
Oil Check	Page 17
Technical Info	Page 18
Technical Info	Page 18.1
Assembly Instruction Trike	Page 19
Assembly Instruction Trike	Page 20
Assembly Instruction Trike	Page 21
Glider Suspension	Page 22
Assembly Instruction	Page 23
Start Flight Landing	Page 24
Rescue System	Page 25

Super Thorix

Content

Prior to operation of this paramotor trike the pilot should familiarize themselves with this manual. It contains operating instructions and details pertaining to the maintenance of the Super ThoriX.

The owner needs to become familiar with all aspect of operation and maintenance prior to the use of this motor and Trike. The owner needs also to adhere to laws pertaining to their own country regarding flight restrictions and maintenance as well as what is contained in this manual. Information regarding important updates to this model will be made available via your importer, and published in the relevant national flying magazines under <http://www.freshbreeze.de/en/service/dfgdfg.html>

Please note:-Do not make any flights in turbulent weather conditions through as a paraglider in principle receives its shape only by the internal pressure. This can be established only when normal air flow conditions prevail. You need to fly with increased caution when thunderstorms are near by or forecasted.

Under no circumstances should a pilot fly too close to the storm front. Land if ever in doubt. Other areas in your country will also have flight restrictions and laws of entry. These include but are not limited to military zones, controlled aircraft areas and populated areas. Seek information about an area before taking flight as well as the appropriate licensing.

Super ThoriX ***ThoriX 190***

Introduction

At first bring the engine is an uprate position and attache the two lower cage part to the frame.



Afterwards fix the upper cage parts



Complete all seven velcro which hold the cage.

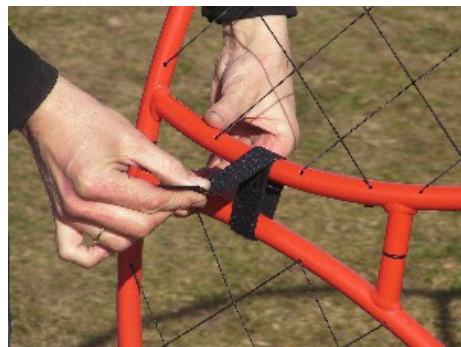

Super ThoriX ThoriX 190

Assembly Intruction

The front frame is pushed forward with the cables in the trike seat and



... interlocked with the two thumb screws. Through this type of lock, the seat length adjustment can be carried out easily.



The rear wheels are easily removable for transport. The inserted spindle is secured by clip pin.
Air pressure 0.4 bar



Bullix

Assembly Instruction Trike

Page 20

Now attach the both Mutli-Function-Tubes to the engine frame on the left and the right side.
On upper holes use the Quick-Pin's to fix. The lower end's of the tubes are secured via velcro.



To hang the engine on the trike, put the engine behind the trike and drives it under the hook.



The multi-tubes must fit properly in the white clips. Be aware that the centering pins fit into the holes of the multi-tubes



BulliX

Assembly Instruction Trike

Page 21

The engine must be secured with two belts on the right and the left side



The push rods are held with rubber ropes in a horizontal position.



To compensate different pilot weights, there are 3 positions for the glider.

Heavy pilots (90+ kg) use the front position. Light weight pilots have to use the rear position.



BulliX

Glider suspension

The glider is mounted into the biners. The brake lines should run here by the lower pulley, so that the brake loop can be achieved in flight at any time.



The start aid is hooked in the A-line shackle.



The correct length from the start aid line is essential to check. The red line of the start aid line must sag slightly when the strap is pulled 90° to the push rod. This must be explained/set by an experienced instructor.



All lines from the glider should be placed in the holder before take off.



The Start

Before starting, of course the wing has to be hooked up to the Bullix in the proper way and layed out correct. The lines of wing need to be in the line retainer and the lines of the wing have to be tolerably stretched.

The superstition of the idea to start the start run just on the rear edge of the wing is wrong and may cause damage to the wing and trike. The peak demand of such a start may harm the pilot suspension and the push rods. The horizontally power can not be braced through the carrying straps and a bend pushrod and/or seat bending may occur.

After you took a seat you need to buckle up and pick up the throttle lever in your hand. Then pick up both brake lines of the wing. Now you can start the engine (warming up the engine before the start run is a must).

Now you give gas little by little (never use too much swing mentioned above) to get the wing started. While starting the wing – always check over both shoulders the status of the wing. From the first moment control the wing and correct it with the brake lines early as possible. But never pull to much brakes – otherwise the wing will fall or get stuck in a $\frac{3}{4}$ position and won't come up for starting.

If something goes wrong in this procedure just abort the start procedure and start again.

If the wing takes his 12 o'clock position above you and the trike gains speed you might want to brake the wing overall a little. This braking will hold the wing in position, makes it more stable and impassible for overshooting or gusts. Sometimes the view to the wing is more important than the direction of driving. A few seconds of full throttle and the trike will lift you off the ground. Depending on the weight, wing size and the front wind the take-off run is about 3-20m

Notice: Adequate space for the starting is self explainable.

Flight:

The flight with trike does not differ much from footlaunching. Through the rubber mounts the vibrations in flight are even less. In long flights the throttle lever can be adjusted for cruising speed and stored in the throttle lever holder if the situation allows it.

Landing

The landing with a trike is much easier as a footlaunched landing. The forward speed does not make a difference. Same as the take off, the landing should be always in the direction of wind. In generally the take off and landing distance is the same in same conditions.

Notice: The wing only „drops“ down when the trike stops. If you do a landing sideways to the wind the danger of tipping is given.

The trike is positiv tested up to 2m/s pitching speed, but is uncomfortable for the pilot. Flare out the wing to make a soft touch down. The engine should be switched off after landing latest. Different procedures are possible and depending of the skills the pilot. If unsure for example, you might want to turn off the engine in flight to avoid the lines get caught in the propeller. Sometimes second approach is worth a try.

Bullix

Start Flight Landing

Page 24



The rescue system can be mounted overhead or behind the seat.
The V-line of the rescue equipment must be guided to the carabiner of the glider . The advantage of the overhead mounting is that the trigger handle can be reached even with the left or the right hand at every time
The rescue equipment must be selected such that the MTOW is considered.

The starter handle is hooked into the eyelet at the top of the right cage.



The propeller is in two parts. Before assembly, he must be plugged together. Attention! Do not plug the propeller halves wrong side



As demonstrated in the picture the 4 blade propeller is crossed mounted. This version isn't available.



Tighten the 2 blade prop screws M8 x 35 with 10 Nm.
Tighten the 4 blade prop screws M8 x 65 with 10 Nm.



We supply the engine with two different gas cap's. One is closed for the transport and the other is vented for flight. Make sure the open cap is in use for flight. Otherwise the engine will stop in flight suddenly. The closed screw cap may just for a short time on the tank. The gas tank can deform and damage under permanent excess pressure. Please check the gas tank before each flight.



The fuel filter is located below the petrol tank and must be checked before each flight



In case the float bowl chamber is empty, use the ball pump to float the carburetor.

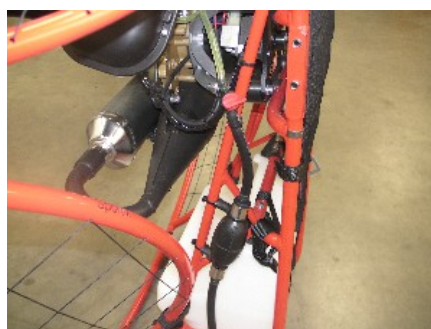

The carb is equipped with a choke lever (1). Try to start the engine at first without the choke. The idle speed can be adjusted with the screw (2).

The screw (3) regulates the air-fuel mixture. To lean the mixture turn left. To make richer the mixture turn right.

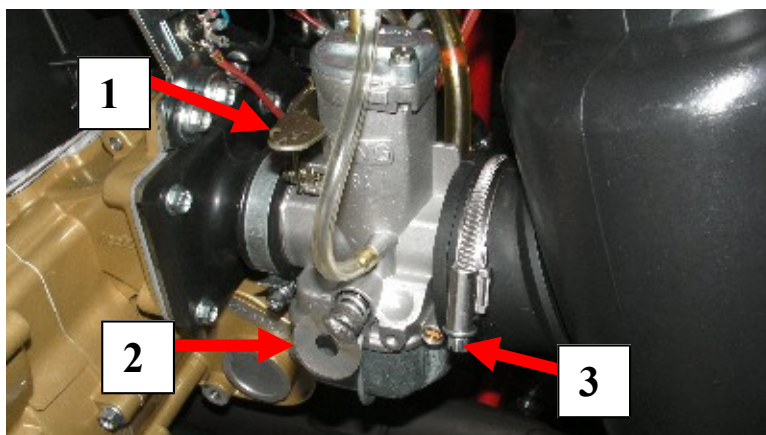

Super ThoriX ThoriX 190

Gas and Oil

The needle should be replaced h after 100. In this case, proceed as follows:
The screws on the carburetor cover unscrew counterclockwise.
The screws remain in the cover.



The slider can easily drawn as a whole out of the carburetor. The needle is placed at the lowest position in the slider.



The needle 6L1 is mounted in the second position from top. When replacement is essential to ensure the order.

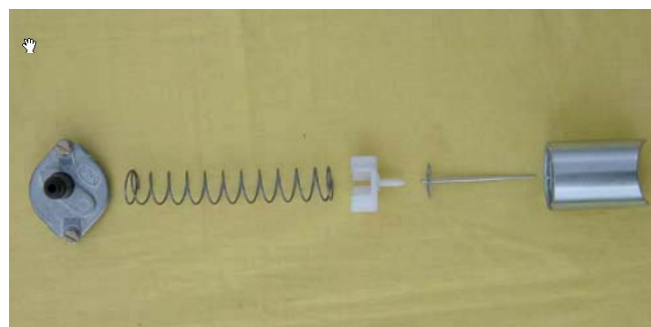

The assembly of the shifter is in the reverse order and can be made to look like the picture.

The slider has a groove, which defines the installation position in the carburetor. The carb cover has just one fitting position

Main jet 165

Idle jet 60

Needle jet 2,72



Super Thorix

Carburettor

The carburetor is fitted with a 165 or 160 main jet. Should it become necessary, to clean or change into another size open the chamber. The red filter, which surrounds the main nozzle, is essential and should not leave off.

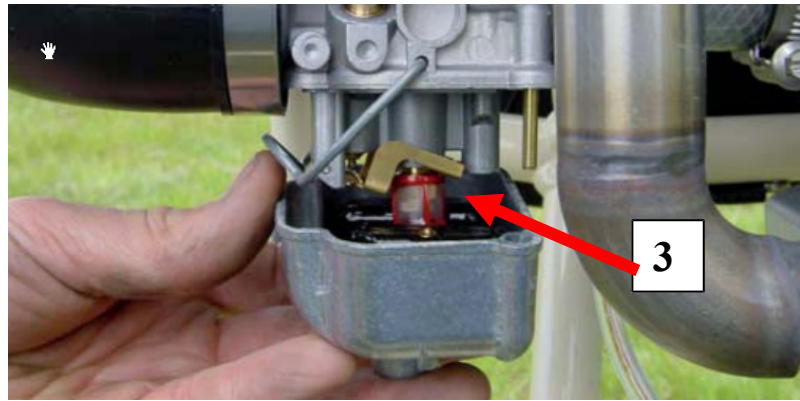

With an 8 mm wrench the mainjet (2) can be changed. Number 3 is the fuel mixture jet size 60

Under no circumstances use a smaller one than 50.

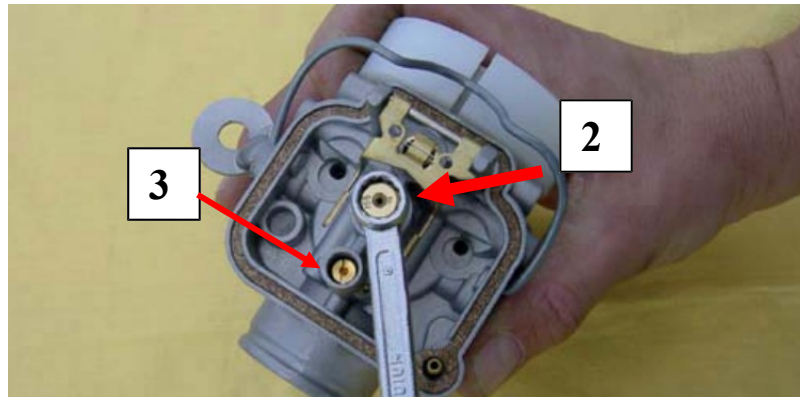

In case your engine is equipped with a WB 37 carburetor so no special choke system is existing. A cold engine needs to be primed.

To prime your engine squeeze the ball pump. Simultaneously press in the carburetor membrane to allow fuel come into the carburetor.

It is important to release the membrane before releasing the pump. Repeat this until you see fuel enter into the carburetor via the fuel line and your finger feels a little pressure.

Now you have the right amount of gas in your carburetor.

Basic adjustment for WB 37 on ThoriX 190

Open screw L 1,1 turn

Open screw H 1,6 turn

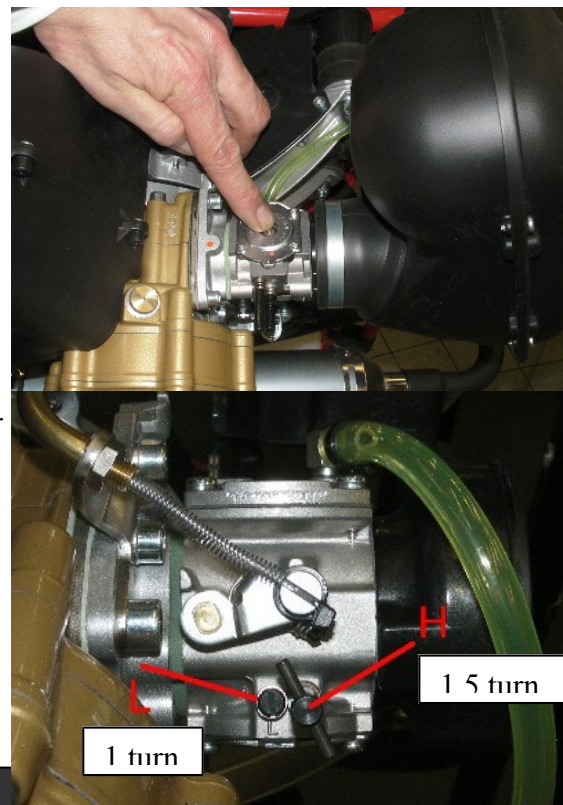

Super ThoriX ThoriX 190 Carburettor

Ensure the place where you start the engine is clear for any people.
Start the engine only on your back or mounted on the trike.
The engine usually start in summer better without choke
The throttle lever should be in in your hand
while pulling the cord. Identify the kill switch in case you need
to stop the engine.
After a tough pull the engine should start easy with Flash
Starter.
When the engine is at operating temperature, it starts better if a
little thorttle is given.



**THE ENGINE RUNS WITH A 1:50 FUEL/OIL MIXTURE
(2% 2T CASTROL SUPER WITH 95 OCTANE FUEL).**

**!WARNING! !DO NOT START
ENGINE ON THE GROUND-THERE
IS A
HIGH INJURIE HAZARD**

**Super ThoriX
ThoriX 190**

Start the engine



The Super ThoriX has two different pushrods. The left bar is turned outwards. This compensates the negative torque of the engine very effectively. It eliminates the permanent left spin direction in flight when the engine is running under load.

The propeller from ThoriX 190 turns opposite. Therefore the right pushrod is here turned outward.

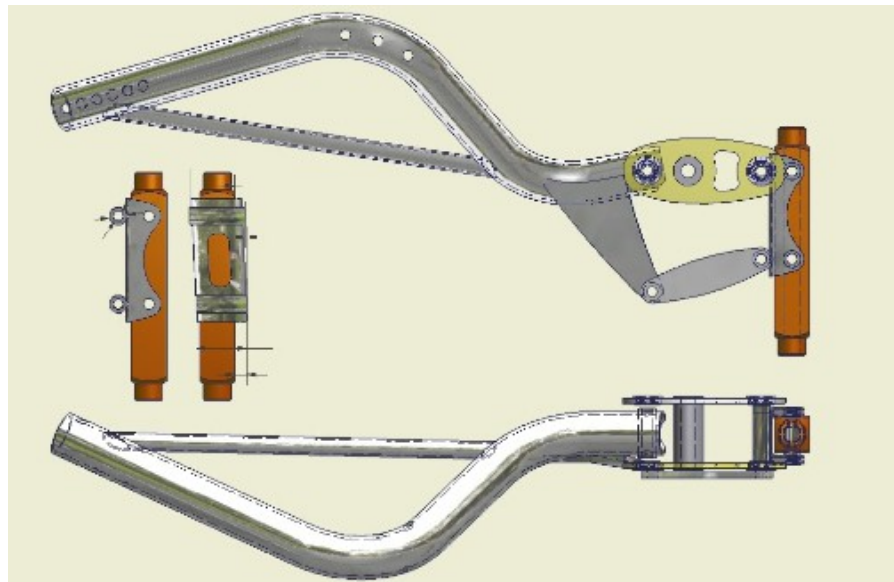

Super ThoriX

ThoriX 190

The harness is mounted on top of the backframe. Ensure the velcro is doubled over and secured.



The pushrods are mounted via the quickpins. It is easier if you always leave the quickpins in the pushrods.

Mount the lower quickpin at first and be sure to include the plastic cover plate.

Attach the pushrod with the upper hole to the frame at last also with the quick pin.



This chest strap prevents slipping off the risers. With the integrated pipe can draw attention to themselves in emergency situations



Super ThoriX/ThoriX 190

The carrying straps need to be latched to the lower part of the frame (as shown in picture). You can hear a click when they are attached. Check both sides when completed.

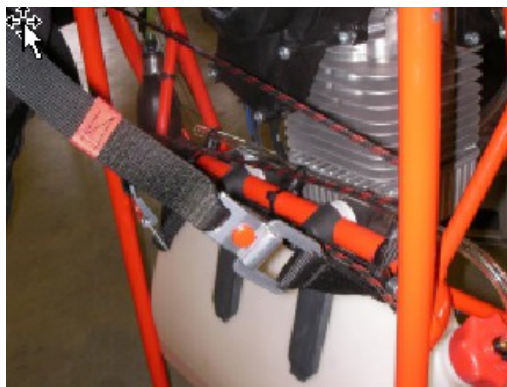

The built in rescue system is integrated into the side of the harness and offers usability and comfort. It is however very important that the reserve bridle runs outside of the pushrods. (See picture). Each time the pushrods are fitted to the frame this needs to be checked.



From there the reserve bridle splits apart and runs over your shoulder to the carabiners.



The end of the V-lines are mounted on the carabiners. Check this.

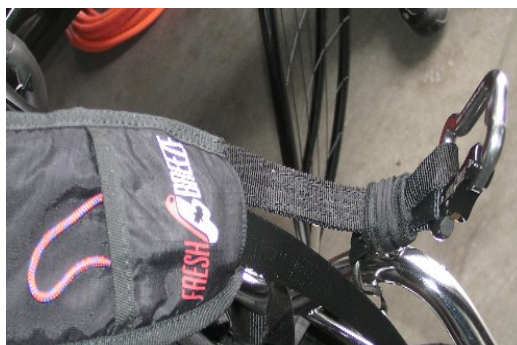

Super Thorix / Thorix 190

Pilotsuspension and Harness

Seat position while flight



Landing position

Hint:

After launching it is recommended to use the kick strap provided to easily slip into the harness. Push your lower back into the back of the harness stretching you legs to gain flying position. This needs to be tested prior to your first flight as the length of the kick strap will depend on your leg length..



Super ThoriX / ThoriX 190

Pilotsuspension and Harness



As people weights vary it is important to set up your motor to ensure your weight will result in a safe and comfortable flight. Test hang your motor to simulate the in-flight position and re test hang after each adjustment. The aim is to have a safe thrust line position as well as a comfortable position to fly in. Use another person preferably an instructor to help you adjust this tilt angle. Aim for between 5-20 deg. A 5 degree thrust line means the thrust is pointing 5 degrees down. The higher the angle the more tilt back. Beware this may result in more difficulty getting out into hang for landing. Higher tilt back angle may also result in pre-mature sitting down on launch.

Factory settings on the low hang bars are the middle position in both holes, test hang in this position first. As a general rule.

Heavy pilots should use the glider position hole **1** and the harness position **3**

Lighter pilots use position **3** for Glider shackle and pos **1** for the harness shackle.

Before you change both settings at once, try one change at a time, as this may produce the results required.

Always be sure yourself, that all shackles are screwed in all the way and are secured with the keyrings (small picture)

Super ThoriX / ThoriX 190

Pilotsuspension

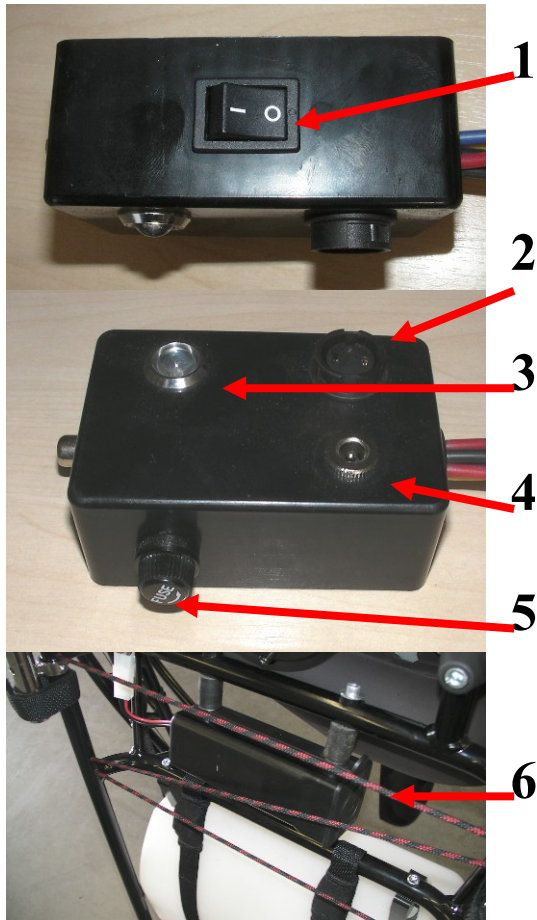

The motor can be equipped with an alternator. This includes an E-box and a batterie. The batterie is recharged in flight. The E-box includes the following:

- 1.ON / OFF
- 2.12 Volt Plug for GPS, Radio ect.
- 3.Controll LED. When flashing altinator is ON
- 4.Plug for heated clothes. 80 Watt at 5500 1/min
- 5.Fuse 500mA
- 6.12 Volt batterie

Super ThoriX / ThoriX 190

Altinator

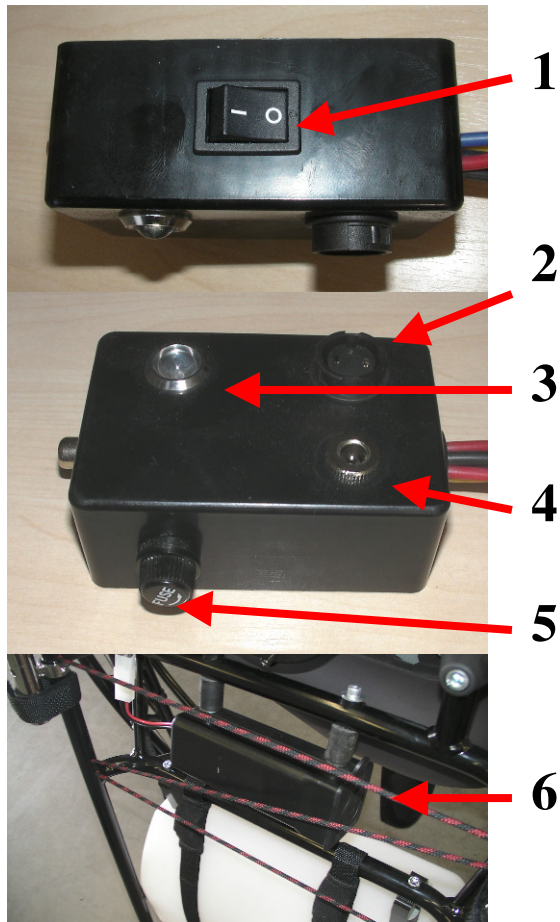

The motor can be equipped with an alternator. This includes an E-box and a batterie. The batterie is recharged in flight. The E-box includes the following:

- 1.ON / OFF
- 2.12 Volt Plug for GPS, Radio ect.
- 3.Controll LED. When flashing altinator is ON
- 4.Plug for heated clothes. 80 Watt at 5500 1/min
- 5.Fuse 500mA
- 6.12 Volt batterie

Super Thorix

Altinator

The throttle lever is secured in your hand via the hand strap. Secure the throttle lever prior to flight. As some methods for launch set up involve taking the brakes first, refer to your instructors advice for the best sequence for launching..



While doing a forward inflation ensure the A-lines don't get caught on the cruise control. Adjust this knob for the optimum position to avoid this getting caught. If you ordered your throttle lever upside down there is less chance for this to occur..



Consult your instructor for the best method for inflation.

Shown in this picture the set up of a powered forward inflation. Now you're ready to start, remember always fly safe!



Super ThoriX ThoriX 190

CHECK BEFORE EACH FLIGHT

- Cage secured with velco on the frame
- Cage in good shape
- Propeller clearance. Only a small clearance to the propeller hub is o.k.
- Propeller without damage
- Killswitch on duty at full throttle
- Fuel mixture 2% and min 95 Octane
- Pilotsuspension and straps without stressmarks
- Sparc plug connector well positioned
- Vented fuel cap in use for flight
- Proof glider, lines and riser for stressmarks or damage's
- Belt and Tension

CHECK ALL 10 HOURS

- Fuel filter once after 10 hours
- Spring on exhaust
- Exhaust for fissures and rubbermount
- Gearoil change once after 10 hours API GL4 and level check

Check all 50 hours

- Wires and it's connections
- Thottlecables
- Change fuel filter
- Replace sparc plug BR 10EG Super ThoriX
- Replace sparc plug BR 9 ES ThoriX 190
- Replace rubbermount from exhaust
- Change gear oil *ELF MOTO GEAR OIL 10 W 40 or Shell Advance Gear SAE 10 W 40 API GL-3*
- Tight all screw's and clamps
- Check inlet diaphragm

Super ThoriX
ThoriX 190

Check and perform all 100 hour

- Piston ring's , clearance pistonring's.Remove the exhaust and check through the exhaust outlet the clearance of the pistonrings
- Check possible carbon deposits in the cylinder head and clean if necessary
- Open the gearbox and check the pinions
- Replace the carabiner from pilotsuspension
- Starter rope
- Intake membrane
- Replace the carburettor needle
- Clean the Carb. chamber

Replace all 200 hours

- Piston complete
- Replace all rubber mount

Replace all 400 hours

- All Bearings from gearbox and engine
- Crankshaft

Glider

- The glider should send to the manufacturer each two years for general check

Engine

- The engine should be checked each year alike how much hours it's used.
- This may take only a trained person..

!!!

**WITHOUT THESE CHECK'S NO WARRENTY OR OTHER CLAIMS!
PLEASE USE ONLY FRESH BREEZE GENUINE SPARPARTS.THIS WILL TAKEN POSSESSION
ALL SAFETY AND STIFFNESS WHICH IS REQUIRED FROM DULV.**

!!!

**BE SURE TO FOLLOW THIS SAFETY ADVICE EVERY TIME YOU USE
FRESH BREEZE MOTORS !**

- USE YOUR ENGINE CAREFULLY. DISREGARDING ANY SAFETY ADVICES AND INCAUTIOUS BEHAVIOUR MAY LEAD TO SERIOUS INJURIES.
- NEVER COME CLOSE OR GRAP INTO THE SPINNING PROPELLER. HIGH RISK OF SERIOUS INJURIES.
- THE ENGINE MAY NOT BE STARTED WHEN IT IS STANDING ON THE GROUND. HIGH RISK OF SERIOUS INJURIES.
- NEVER TOUCH HOT PARTS (ENGINE, EXHAUST). HIGH RISK OF BURNING.
- Unexperienced pilot's should have minimum 90 kg (176 lbs).Otherwise you risk a stall or twist in while of full throttle

S-ThoriX

Check

Page 15

AustriAlpin Powerfly Karabiner sind zur Verwendung als Gurtkarabiner bestimmt. Die am Karabiner angegebenen Festigkeitswerte gelten zur Verwendung für Gurte: (schmale Seite: 20mm/ breite Seite: 45mm)
Die Kennzeichnung auf dem Karabiner hat folgende Bedeutung (Dieses Kennzeichnungsbeispiel dient nur zur Erklärung. Gültigkeit haben nur die eingepprägten Werte auf dem Karabiner)

KN 25 \diamond 10 MONO + BI
| B | | C | | D |

Klammer A: Festigkeit in der Hauptachse des Karabiners in KN
Klammer B: Festigkeit bei offenem Schnapper in KN
Klammer C: Tauglichkeit für Einzelpilotenaufhängung (min 18 KN)
Klammer D: Tauglichkeit für Tandempilotenaufhängung (min 24 KN)

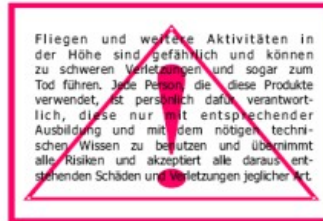
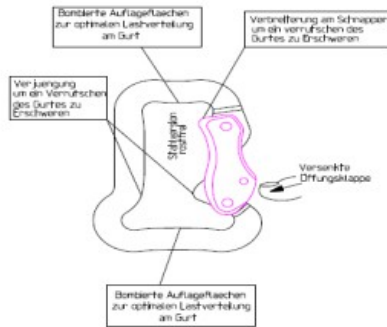

Gebrauchsanleitung

Vor jedem Start muss der Schnapper:

- 1) geschlossen und verriegelt sein
- 2) Verschluss und Verriegelung kontrolliert werden

Kontrollieren Sie vor jedem Gebrauch ob der Karabiner unbeschädigt ist und ob alle Teile einwandfrei funktionieren. Bei jedem Zweifel über die Sicherheit darf dieser nicht mehr verwendet werden. Beachten Sie, dass nur bei fachgerechtem Einsatz die angegebenen Festigkeitswerte erreicht werden, und eine sichere Funktion gewährleistet ist. Beim Einsatz in Gleitschirmen bzw. Gurtzeugen ist darauf zu achten, dass der Karabiner in die dafür vorgesehenen Schlaufen eingehängt wird, da nur diese die nötige Festigkeit aufweisen und für optimales Verhalten des Schirmes konzipiert sind. Der Öffnungsmechanismus ist so konstruiert, dass eine unbeabsichtigte Öffnung weitgehend ausgeschlossen wird. Trotzdem muss darauf geachtet werden, dass kein Gegenstand (Gurt, Leine, Band usw.) die Öffnungsklappe berühren oder betätigen kann. Der Anwender sollte genauestens über die Geräte, die er verwendet Bescheid wissen sowie über die nötige Erfahrung verfügen, um diese fachgerecht einzusetzen. Sollten Produkte von mehreren Personen verwendet werden (z.B. Flugschulen, Trainingszentren usw.) empfehlen wir eine systematische Überprüfung. Es ist darauf zu achten, dass AustriAlpin bei nicht sachgemäßer Verwendung, keine wie auch immer geartete Verantwortung und Haftung übernimmt.

Reinigung, Wartung, Pflege:

Reinigen Sie den Karabiner mit reinem Wasser. Für eine möglichst lange Funktionsdauer ist es notwendig, alle Gleitteile an ihren Gelenken mit einem Tropfen Öl zu schmieren. Die Aufbewahrung sollte in gereinigtem und trockenem Zustand, in trockener Umgebung auf nicht metallischem Untergrund erfolgen. Chemische Einflüsse bzw. Temperaturen über 150°C sind unbedingt zu vermeiden.

Der Karabiner darf nicht mehr verwendet bzw. muss getauscht werden wenn:

- der Schnapper nicht mehr selbstständig schließt oder sichert;
- Beschädigungen, die eine Sollbruchstelle darstellen könnten, vorhanden sind;
- der Karabiner überhitzt oder überlastet wurde;
- die Gebrauchsdauer erreicht ist. Gebrauchsdauer:

POWERfly - Inox Stahl: 1.500 Flugstunden oder 5 Jahre

Super ThoriX
ThoriX 190

Carabiner

Oil Control, Drain Screw and Belt Tension

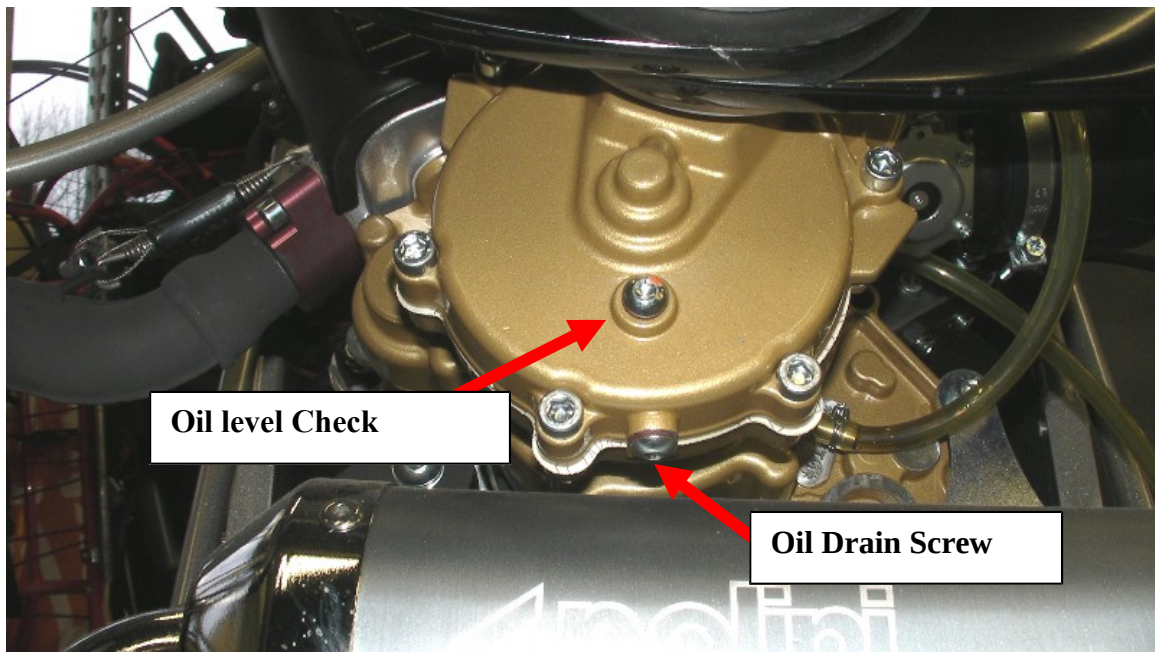

Specification: *ELF MOTO GEAR OIL 10 W 40 or Shell Advance Gear SAE 10 W 40 API GL-3*

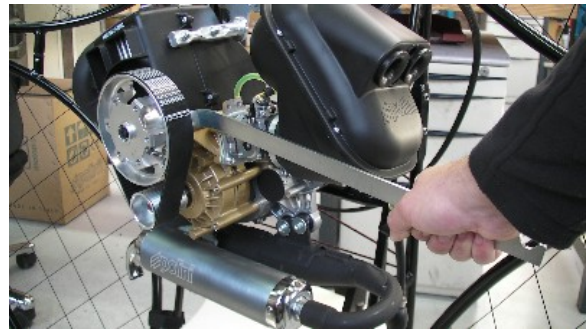
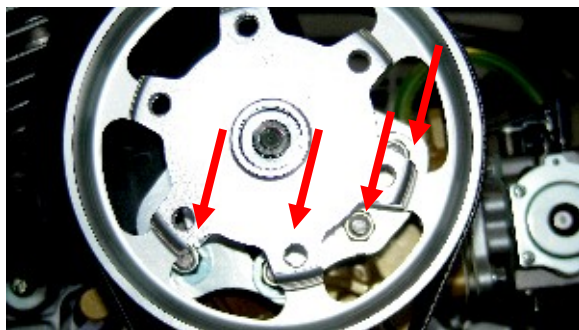

Belt Tensioner

Undo the 4 nuts. Tighten the belt with the special lever, and fix the nuts again.
Poly V PJ 508 15 Rips

Super Thorix/ Thorix 190

Oil Drain
Belt Tensioner

Engine	1 Cylinder 2 Stroke
Cooling	Fan cooled
Bore/Stroke	64 x 60
Capacity	193 ccm
Power	21,3 kw bei 7400 1/min
Cylinder	Aluminium mit Gilnisilbeschichtung
Compression ratio	11,4:1
Intake	Membrane controlled
Carburettor	Bing 84 / WB 37 at Poly V transmission belt gear box
Noisefilter/Airfilter	AGD
Ignition	Contactless
Altinator	80 Watt at 5500 1/min
Petrol	95 Oktan or higher,unleaded
Gearbox	Gear ratio 2,8:1 with centrifugal clutch in oil / Poly V transmission belt gear box 2,83:1
Starter	Manual starter Type „Flash“ / E-Starter
Exhaust	Resonator with silencer
Fuelconsumption with Trike	4 Liter/h with 29 qm Glider 80 kg Pilot
Propeller Direction	Clockwise / anti clockwise at Poly V transmission belt gear box

Torque

Cylinderhead Screws	14 Nm
Crankshaft Clutch Side	60 Nm
Crankshaft Ignition Side	40 Nm
Propeller Central screw	40 Nm
Spare Plug	20 Nm
Crankshafthouse	8 Nm
Centrifugal Clutch (Nut)	80 Nm
Countershaft	60 Nm

Abmessung	Regelgewinde									
	Vorspannkraft (kN)					Anziehmoment (Nm)				
Festigkeits- klasse	4.6	5.6	8.8	10.9	12.9	4.6	5.6	8.8	10.9	12.9
M 4x0,70	1,29	1,71	3,9	5,7	6,7	1,02	1,37	3,0	4,4	5,1
M 5x0,80	2,1	2,79	6,4	9,3	10,9	2,0	2,7	5,9	8,7	10
M 6x1,00	2,96	3,94	9,0	13,2	15,4	3,5	4,6	10,0	15,0	18,0
M 8x1,25	5,42	7,23	16,5	24,2	28,5	8,4	11,0	25,0	36,0	43,0
M 10x1,50	8,64	11,5	26,0	38,5	45,0	17,0	22,0	49,0	72,0	84,0
M 12x1,75	12,6	16,8	38,5	56,0	66,0	29,0	39,0	85,0	125,0	145,0
M 14x2,00	17,3	23,1	53,0	77,0	90,0	46,0	62,0	135,0	200,0	235,0

Super ThoriX ThoriX 190

Technical Info

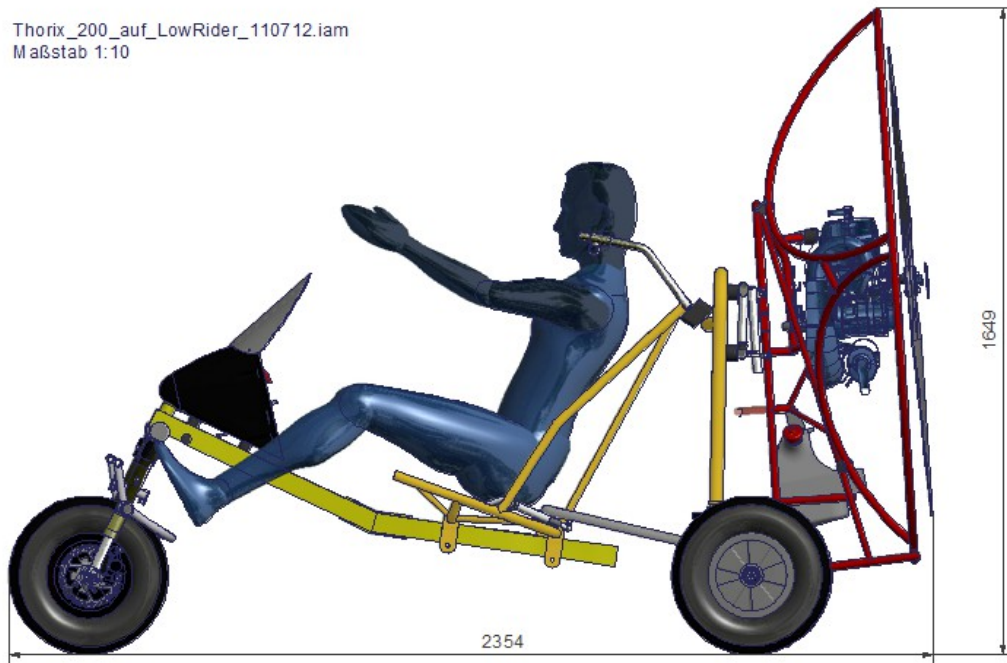
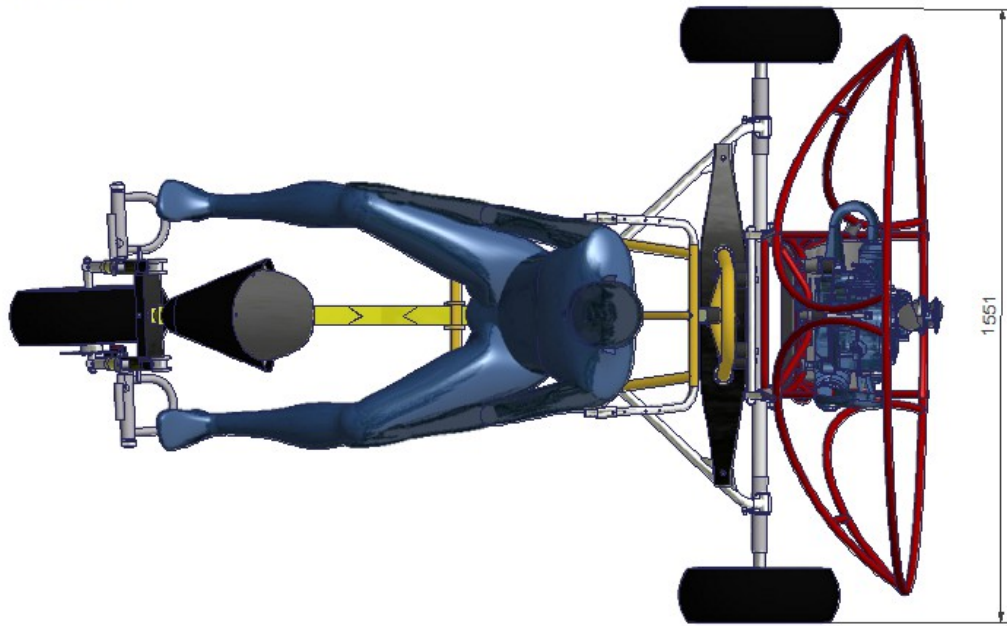

Super Thorix Thorix 190

Technical Info

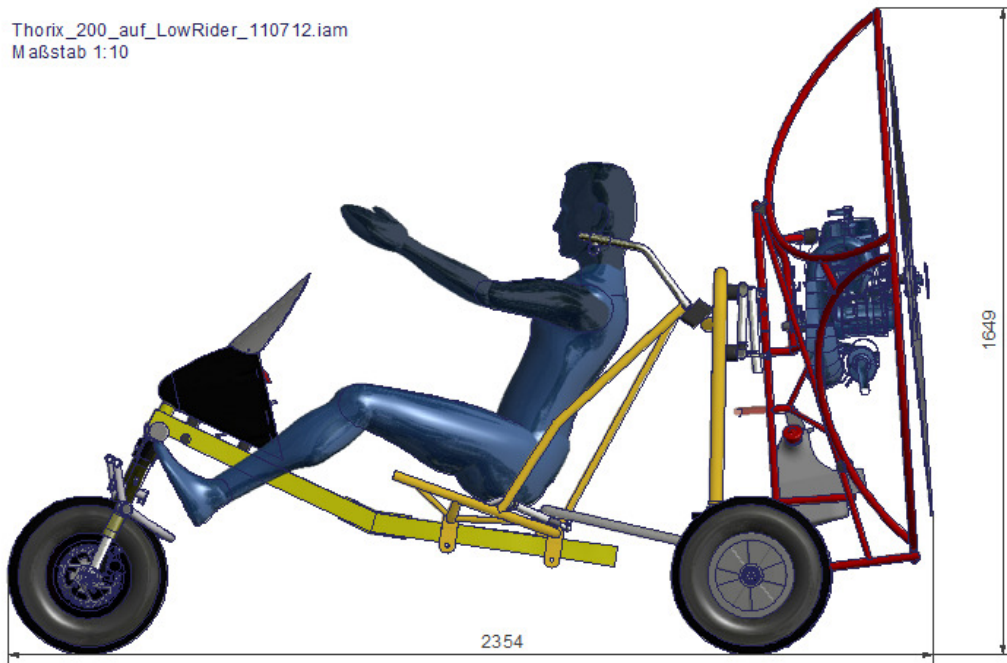
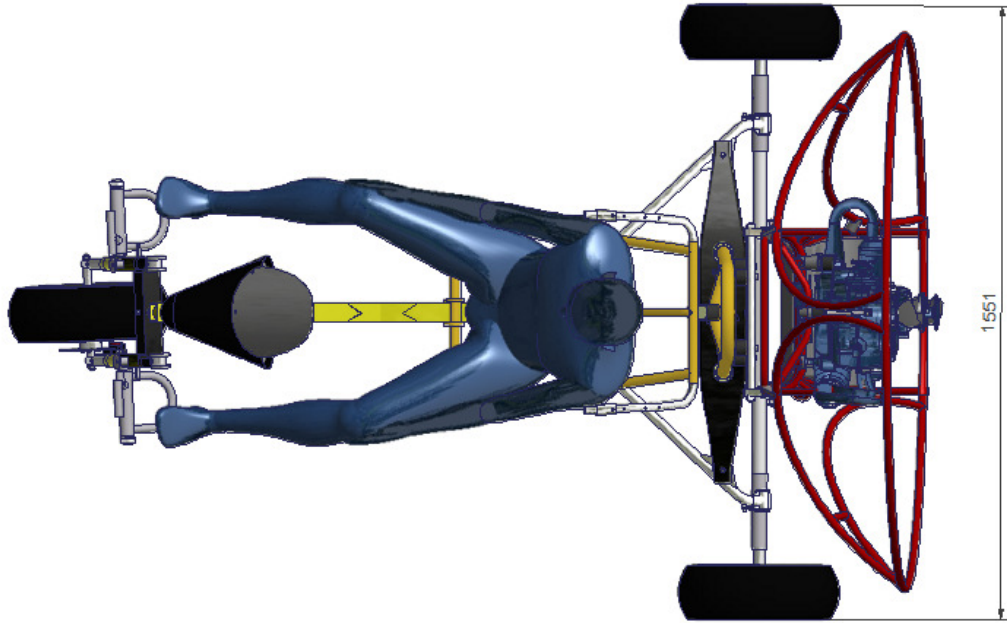

Super Thorix

Technical Info

Assembly
Intruction
BulliX



If all parts of the trike's are available, the trike seat is raised first.



Now I take the front frame with the cockpit

