



ASSEMBLY

OPERATION

MAINTENANCE



# SOLO MANUAL



ASSEMBLY THE MOTOR	03
TECHNICAL DATES	06
FUEL AND OIL	07
CARBURETTOR AND INTAKE SILENCER	08
ENGINE	11
PULL STARTER	14
GEARBOX	15-16-17-18
PROPELLER	19-20
ELECTRIC Standart	21
ELECTRIC Digital	22
POWER IGNITION SYSTEM	23
E-STARTER	24
EXHAUST	25
THROTTLE RESPECT	26
THROTTLE AIRBOSS	27
HARNESS	28-29
WINGMAN CB	30-31-32
WINGMAN CBi	33-34
PRE-FLIGHT CHECK	35
CHECKLIST	36-37
SAFETY ADVISE	38

## TABLE OF CONTENTS

# SOLO MANUAL



Open the package with care. Do not use long knife. Parts inside the carton could be damaged.



Check the parts and proof for completeness.



Bring the four cageparts together and fix with velcrostraps.



Put the motor in front of the completed cage.



## ASSEMBLE THE MOTOR

# SOLO MANUAL

Take the motor and press the cage against the black clipse. Inside the black clips is a bolt which belong in the hole of the cage.



The cage should fixed against the frame with the velcro.



After assembling all velcro's should tighten again.



## ASSEMBLE THE MOTOR

# SOLO MANUAL

The backstuffing will fixed also with velcro. The upper and lower ends from backstuffing turn around the upper and lower rope.



In case that you have a shellform-backstuffing fix it on the left and right side.

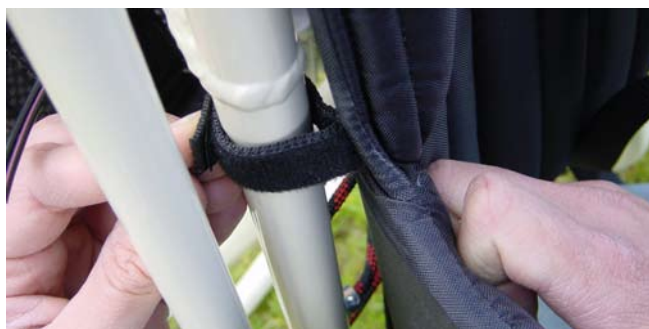

The Shellform-backstuffing prevent that the motor will turn to cause from torque.



Most maintenance you can make by yourself with the original tools.

**CONTENTS:**

- Hexagon 4/5/6 mm
- Wrench 8/10/24
- Wrench for sparking plug and screw driver
- Beltdressing



**ASSEMBLE THE MOTOR**

Motor	Solo 210ccm
Type	2 stroke, 1 cylinder
Power	12 kW
Cooling	air
Starter	manual / e-starter
Carburettor	Bing 84,32mm
Exhaust	Resonator
Propeller	2-blade
Diameter	38"-48" (96-122 cm)
Weight	50 lb (23 kg)
Tank capacity	10 liter
Max. start weight	308 lb (140 Kg)



**NEXT DATES ARE DEPEND FROM:**

**WEATHER, ALTITUDE, PILOTS WEIGHT, GLIDER AND SIZE AS WELL AS ATMOSPHERIC HUMIDITY:**

Consumption	around 3 l/h
Flight duration	up to 3 h
Rpm	0-5800 1/min
Propulsive force	up to 132 lb (60 kg)
Climbing rate	up to 2 m/sec.

**RESULT FROM THROTTLELEVER-POSITION, FLIGHT-LEVEL, GLIDER AND SIZE AND PILOTSWEIGHT FOR THE CONSUMTION:**

Gas lever low output	low consumption	
Gas lever high output	high consumption	
Low flying altitude	low consumption	
High flying altitude	high consumption	
Small canopy	high consumption	high speed
Large canopy	low consumption	low speed
Light pilot	low consumption	low speed
Heavy pilot	high consumption	high speed

**TECHNICAL DATES**

**ENGINE  
MANUAL**



The motor will delivered with two lid's. The first is for flight with a small hole. The second lid is closed for transport. If you try to fly with the closed one the motor will have a "in flight shut down" after a while. It's will establish inside the tank a vacuum. The carburettor get fuel from tank through gravity.

The closed lid create inside the fueltank negative or positive pressure. This can deform the fueltank. Before you start the engine check the fueltank.

The fuel comes from tank through this filter. Check before flight.

### IMPORTANT INFORMATION

THE FUEL SHOULD HAVE 98 OCTANE OR 100 LL. THE BEST OIL IS CASTROL 2T. MIX 2 % IN ADDITION TO THE FUEL.

FOR THE FIRST 10 H MIX 4 % IN ADDITION TO THE FUEL. IN THIS TIME USE FULL THROTTLE VERY CAREFUL.

Fasten the velcro around the fuell tank permanent. Check the gap between fuell tank and exhaust before each flight.

This picture demonstrate a closed petroltap.

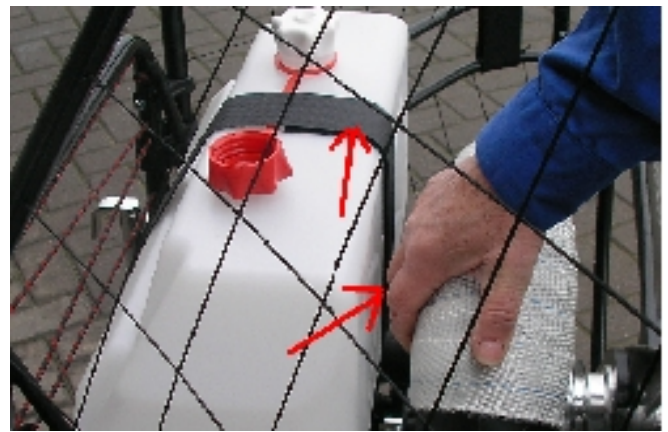

## FUEL AND OIL

# SOLO MANUAL

The Intakesilencer is fixed on two positions. One with a clamp on the carb and one with a rubberline on the top.



In some flying areas it's necessary to use such a airfilter. Use only original parts. Otherwise you risk to loose power.



#### **HOW I CHANGE THE NEEDLE?**

Open the lid with the two screws and pull out all parts which are hanging on the cable.



## ***CARBURETTOR AND INTAKESILENCER***

# *SOLO*

## *MANUAL*





Press the spring together and loose the cable from slider. Now you hold slider and lid apart in your hand. The needle is now loose inside the slider. At our factory we installed the 6L1 in the top position.



Here you see succession from:  
Lid/spring/giude piece/needle with ring/slider

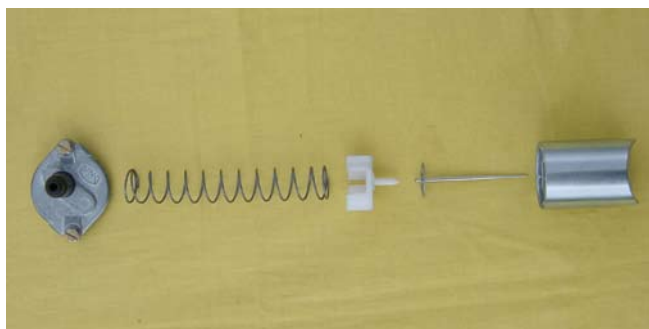

### **WHY I SHOULD CHANGE THE MAIN JET?**

Each motor will checked and testet before he leave our factory. During this time we find the suitable jet. Nevertheless the motor is running bad at your first trial. At full throttle the motor runs rough (rpm less than 5600 1/min).

### **THE REASON IS:**

Other metrologic conditions, higher altitude, more humity, higher temperatur. Normally the main jet is 160. Replace this into a smaller one (155).

### **HOW TO CHANGE THE MAINJET?**

Press the bow back. With the 8 mm wrench screw out the jet.

### **ATTENTION:**

Do not loose the small red filter.

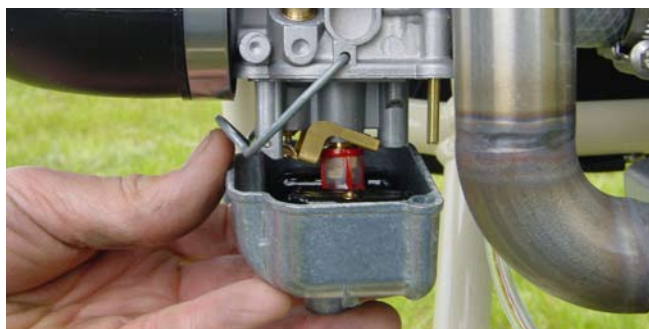

## ***CARBURETTOR AND INTAKESILENCER***

# **SOLO**

## **MANUAL**

Overflowing Carburettor. Fuel comes out of the two small tubes. The two swimmer regulate the niveau inside the carb. To reduce the quantity in the carb bend the little tongue careful.



If you hold the carb up side down, the swimmer for is not parallel to the carburetor case. If the carb overfloat while using the motor the for should look a little bit more upward.



Before you start the cold motor press down the choke. Start the motor and after a few seconds release the choke.



The big screw regulate the idlerunning.  
Turning right-high rpm. Turning left lower rpm.  
The idlespeed should round about 2600 1/min.  
The smaller screw is responsible for fuelmixture in idle.  
Turning right-rich.Turning left-lean



## **CARBURETTOR AND INTAKE SILENCER**

# SOLO

## MANUAL

FRESH BREEZE  
POWERED PARAGLIDER

This picture demonstrate the nacked motor.

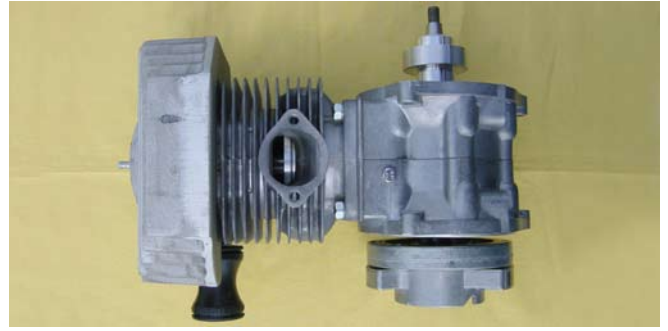

In flight the motor will become very hot. The most stressed airea are the piston and the rings.Remove the exhaust and have a look to appearenced piston with it's rings. Test it with screwdriver.The rings should be loose inside the slot.



### HOW TO REPLACE THE PISTON?

At first remove the four nuts from the feed of the cylinder.

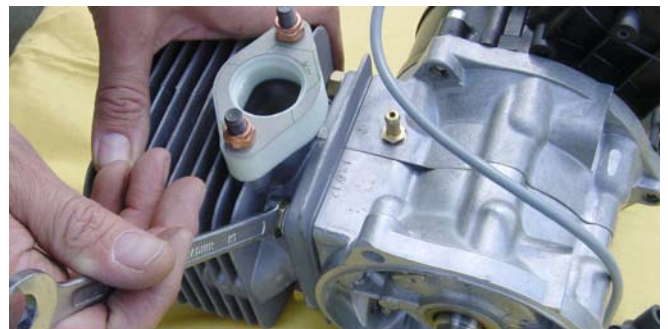

Now draw off the cylinder from piston.



## ENGINE

# SOLO MANUAL

Before you pull out the gudgeon pin remove the safety ring on both sides. Than press out the gudgeon pin.



This picture demonstrate the spezial tool how to remove the safety ring.



The piostonrings can remove and replace by hand.



To remove the head loose the 6 x 40 mm allen key screws. After that you can take away the head. To re-tighten this screw you need 14 Nm torc.

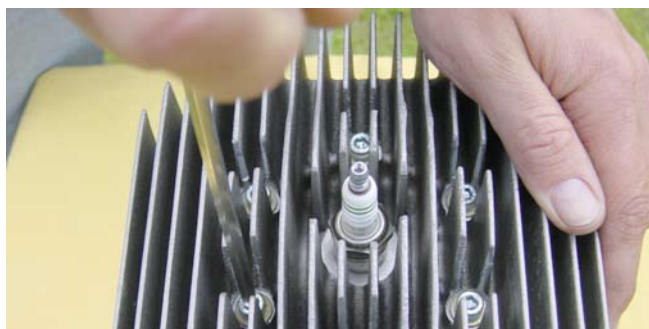

## ENGINE

# SOLO MANUAL

## HOW TO CLEAN THE DECOMPRESSIONHOLE?

After many hours in service time the decompressionhole can closed with carbon. If you use low quality oil it will close earlier. Use the oil "RS 2 T".

To reopening the hole use a 3,5 mm drill. Bore from top and from inside the cylinderwall with an angle from 45°.



To seal the head use our special high temperature liquid sealing.



**ENGINE**

**SOLO**  
MANUAL

## REPLACEMENT OF THE STARTERROPE:

Unscrew the starter-lid, take off the façade plus finger. The white disc should now be removed by pressing it against the tension-force.



The white disc can now be taken out of the lid.



The starter-rope can be pulled out of the disc.



To give the starter-rope advanced tension one, place the rolled up into the slot and rotate three times.



## **PULLSTARTER**

# SOLO MANUAL

The power-transmission of the gears happens via a Poly V Belt (725 or 730 8 PK). The transmission ratio equals 1:2,57. The number of the revolution at full load equals 2350 rpm. The lifespan of the belt is aprox. 50-100 hrs. Too little tension shortens the belt lifespan drastically.



During maintenance check the belt before each flight. The belt should not be able to be turn over 45° degrees. After the first flight it is essential to pay special attention to the belt.



### HOW TO TIGHTEN THE BELT?

1. Loosen the central screw (24 mm).
2. Lift the rotor-hub with the tension-nut 8mm (13mm tool) in order for the belt to either tighten or subside, thus the belt can be loosend. Turn right-belt tighten. Turn left-belt loosen.
3. Tighten central screw (36 NM).



## GEARBOX

# SOLO MANUAL

# SOLO

How do I change the belt?

1. If an electronic-starter is fitted at the engine, the pinion must be dismantled.

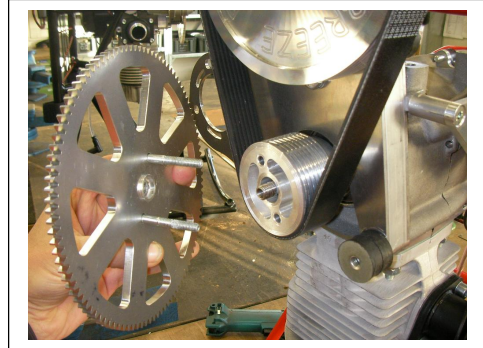

2. Central-nut M16x1, 5 (key distance 24 mm) unscrew a little.

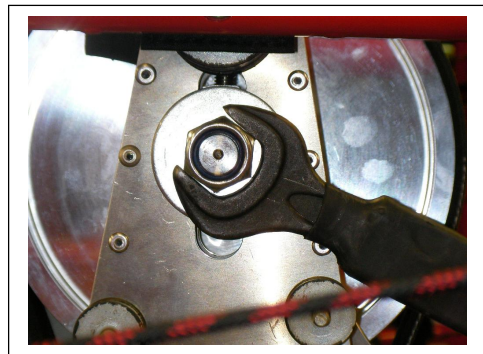

3. Unscrew the 6 mm nut
4. Undoing thread pin with inside hexagon key.
5. As far as, the propeller-hub can be lowered through releasing the stop nut, now the belt can be taken of the pulleys.  
The new belt can be established now for tightening the screws we proceed in a reversed order.

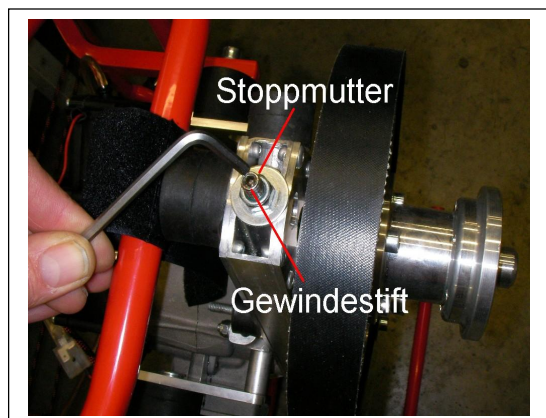

## GEARBOX

# SOLO MANUAL



## HOW TO REPLACE THE BELT?

1. Loosen the central-screw
2. Loosen the belt with tension-screw.
3. Screw in the piston-block into the spark-plug-hole



5. Unscrew starter-pinion



6. Take off belt.

7. Place the new belt onto the pulley.

The re-fitting happens in the reverse order.



If the belt makes squeaking noises in spite of the proper tension, then spray twice onto the lower pulley. If the belt is slipping in spite of proper tension, then it needs to be replaced.



## GEARBOX

# SOLO MANUAL

Tighten/change the belt from model year january 2009



To loosen the clamp from the exenter propellerhup unscrew the bolt with allen key 6mm



To tighten the belt use the allen key 10 mm and turn the whole propeller hub clockwise.

| Gear

# SOLO MANUAL

The propeller consist of the two parts which, put together, measure up to 122 cm in length. The weight is ca 900 gram. The propeller is made of gfk or cfk, which allow for small repairs. But it is essential that after repair is accomplish, the propeller gets balanced out again.



The propeller is fixed onto the hub with 6 screws. Tighten the propeller, use 12 Nm torc.



### HOW TO BALANCED OUT THE PROPELLER?

The propeller has to be placed vertically onto the balancing-out equip-ment. If turns to one side, then drill a 3,5 mm hole into the lighter half of the propeller.

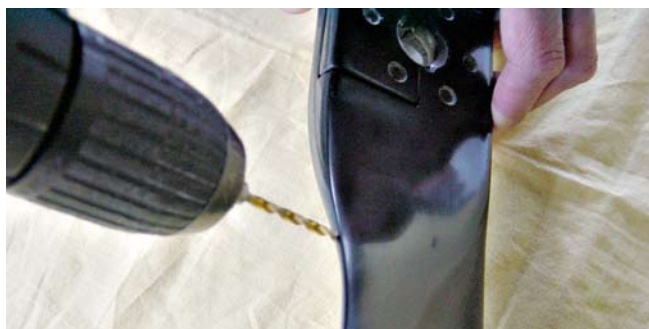

Then fill only as much resin into this hole until the propeller does not want to turn to one side only.



## PROPELLER

# SOLO MANUAL

Likewise proceed as above in the horizontal position.



**ATTENTION:**

An imbalanced propeller creates unnecessary vibration in the engine and can destroy many of its components.



**REQUIRED MATERIALS FOR REPAIRS AND BALANCING-OUT!**

The propeller balancing-out-resing with hardener, syringe and a stored shaft for a free turning of the propeller blades

**WHAT DO I REQUIRE FOR REPAIRING THE PROPELLER.**

Fiberglass-spatula and abrasive paper.



Here now an example when a propeller blade must not be repaired again. If the damage is too large, then repair is dangerous. The repair soft has not enough grip and may fall off when the propeller turns at high revolution. Danger of accident is thus programmed.



**PROPELLER**

**SOLO  
MANUAL**

# Wiring diagram „standard“ ignition ( E-Starter ) 11/2008

12 Volt connector

## Monster / Solo

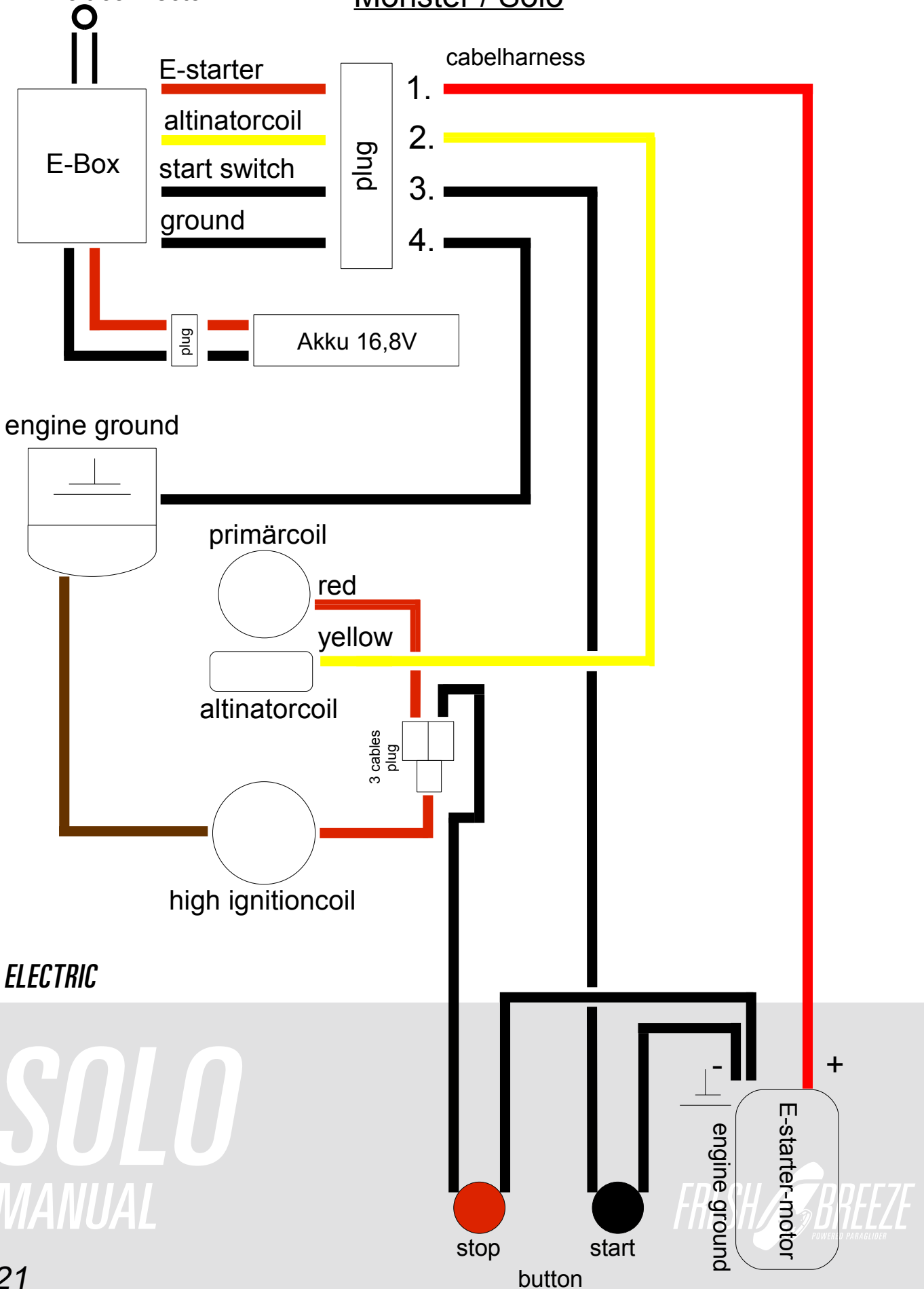

**ELECTRIC**

**SOLO**  
MANUAL

„SOLO“ Wiring diagram „digital“ ignition ( E-Starter ) 11/2008

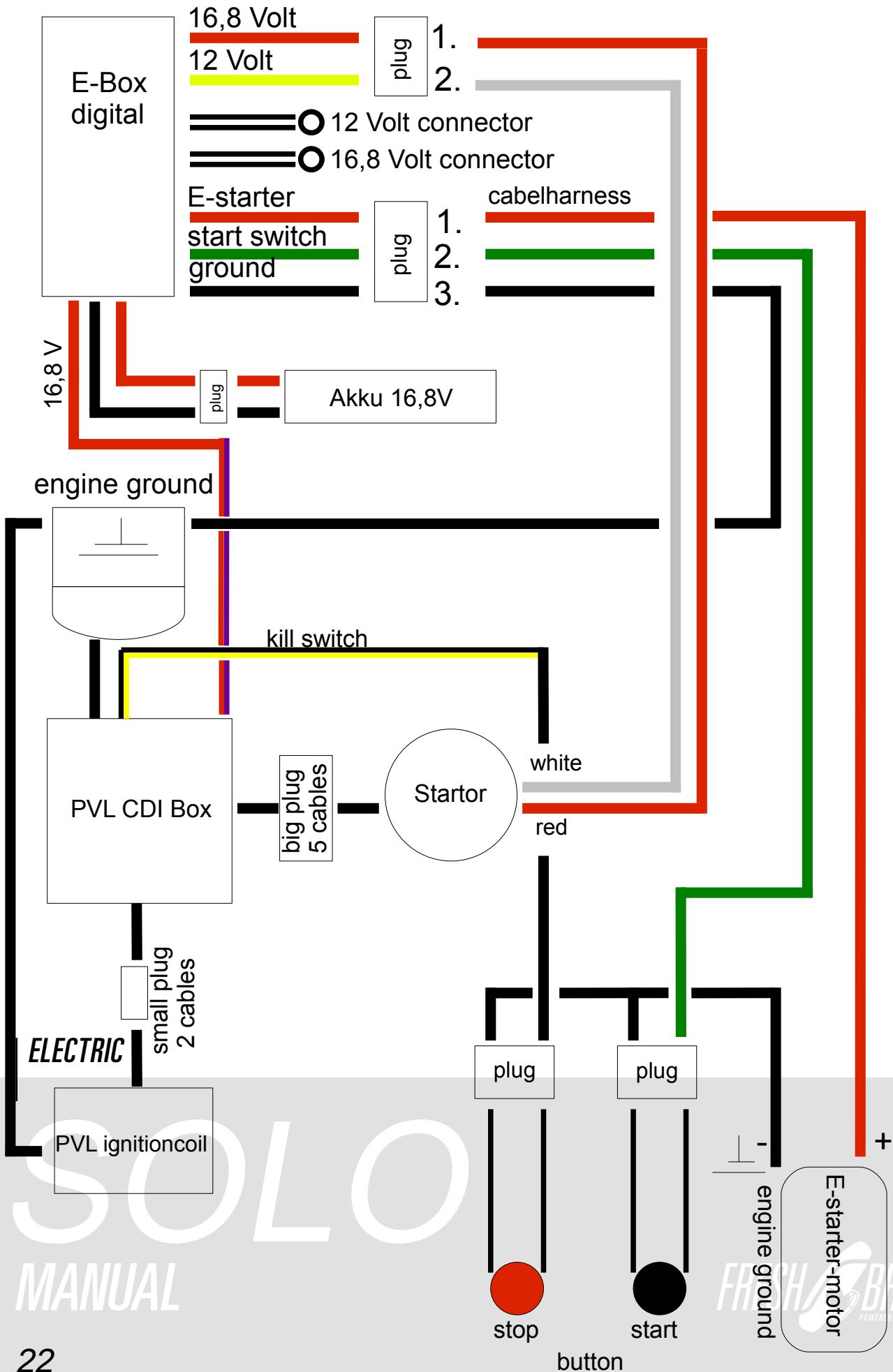

SOLO  
MANUAL

FRESH BREEZE  
POWERED PARAGLIDER

The engine is equipped with a powerful and service free ignition system. It consist of the components: stator, loading-coil of the ignition, generator coil for the supply of electricity and rotor. To be able to work on the coils, the following should be taken care off.



Remove the complete ignitionbox including the lid of the starter. Now the rotor with the starter-pot is visible which is held into place by it's central screw.



Once the central screw has been removed, the rotor can then be pulled off via a puller. Because the rotor has to be in a specific position to the crankshaft, the rotor with a suspension-disc on the crankshaft is preordained.



To fine-tune the ignition timingpoint one has to loosen the two security screws of the stator. Turn the stator to the left maximally to the furthest point, now turn ca 2 mm to the right again. Retighten the security screws. The ignition timingpoint has now its correct adjustment. When reassembling take special care of the correct distance of the contact-test that the distance of 0,25 mm is observed and if nessecary readjust.



## **POWER IGNITION SYSTEM**

**SOLO**  
MANUAL

If the engine is equipped with an e-starter, the power can be turned on just by pressing the button on the throttle. The accu is fixed on the side of the frame and sits in a holster. The accu-pack consist 14 x 1,2 Volt Nicad cells with max 1700 mAh.



The cogwheelplay of the e-starter should be checked after dismanteling the e-motor and need returning if nessecary. In order to accomplish this the M4 screws and the security clamp needs to be loosened. The e-motor can now be adjusted. The individual theeth of the cog should engage properly. To little cogwheelplay prohibits the light/smooth running of the cogs at the start, Is the cogwheel too large, then the theeth of the pinion will die to early. The cogwheelplay could change again after tightening, then a re-check is essential.



Beside the Accuholster there is a switch with 0 and 1. Set on 0 the engine can't be left running on the e-starter. Set on 1 the e-starter is functioning and ready to go. The Accu will only charged while running and with the switch on at the position 1. Look to the backside of the aluplate you see the controller with the coolingrips.

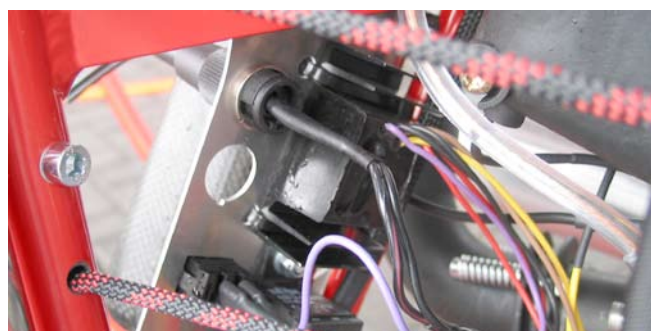

Via this plug a voltage can be transmitted. The dynamo has a limit of max. 24 VA.



## E-STARTER

# SOLO MANUAL



The engine is equipped with a resonance exhaust which allows for an increase of performance and a decrease of excess noise. The white wrap around tape is made of fiberglass and gummen up with silicon.



The complete exhaust is suspended flexibly as to prevent vibrational eruptions.



To keep the exhaust flexibly mobile we chose different types of fixtures. One is a rubber connection on the gear-plate and two a stress-bearing spring-gasket at the entry and the exit.



After 10 hrs the sealing-rings and their fasten screws needs to be checked. The screw you have to changes each 25 hrs.



## EXHAUST

# SOLO MANUAL

The throttle is taken according to the building kind into the right or left hand. The strap has a variable seize change. Before start the strap should be attracted firmly.



The Respect-throttle-lever has in each case a switch at the tube. The one is for the starting the engine.



The other one for killing the engine.



The thottle has also a travelling locking. After reaching the desired hight of flight, the throttle can be fixed via the clasp-lever. Since long holt of the throttle is hard in hand, the throttle can be placed in position onto the legs. The hand are now free for other things.



## **THROTTLE RESPECT**

# SOLO MANUAL

The Airboss throttle-lever has also a button for killing the engine and where appropriate about one for starting the engine, if an electric starter is available.



First the throttle is taken into the hand...



...after that the steering line and at last the A-riser are grasped.



This picture clarifies the handling of the riser and the throttle during the start.



## **THROTTLE AIRBOSS**

# **SOLO MANUAL**

This harness is specially constructed for motoring enterprises. Throughout the usage of the machine, ensure that no loose ends are able to get into the propellerblades. The suspension for pilot can be permanently in the snap links.



The harness is secured via 3 springlocks; tow legs spring and one breast spring lock. It has two adjustments possibilities. One there are the buckles which are fastened onto the front of the seat. At the start these should be pulled on lightly, as to make the climbing into the harness easier at the lift-off. Before landing it is advisable to lower the seat fully, to enable a maximal favourable touch-down position. The leg loop does not need to be pulled too tightly.



All other adjustment options are regulated while flying. Are the straps pulled right and left, then one sits up straight, are they loose a slight back prone position can be adopted.



The harness has also two pockets, which are easily reached at flight.



## **HARNESS**

# SOLO MANUAL

Now one kneels in front of the engines and pulls the carrying straps over the shoulders.



Thereafter the pilotsuspension has to be hang into the dropping device of the engine. Usally the hind most hole is used for this. The dropping device should be activated at pending danger, for example at a water landing, fire at high altitude or a tree touchdown. The activation occurs when the two strings of the dropping device are pulled outwards. Because the engine is now not hanging over the suspension of the chute anymore, the pilot will be in a brought into a strong reclining position. Thus the engine can now slide easily over the shoulders. The landing proceeds from now on without the engine.



## HARNESS

# SOLO MANUAL

Now one get up with the whole engine and goes to the glider. The glider will then be hang into the springlocks for the pilots suspension.



After all has been done, the throttle and the break-loop had to be taken into the hand. The engine will now be started and the starting run can begin.



## RESCUE SUSPENSION

The picture shows an example of how to fasten the rescuedevice using the V-line. The rescuedevice should be connect with the pilot suspension using the V-line. So it's an optimal landing position in case of a possible release. The rescue-device should not be hung in the harness using the spring hooks, because of supine in rescue release.

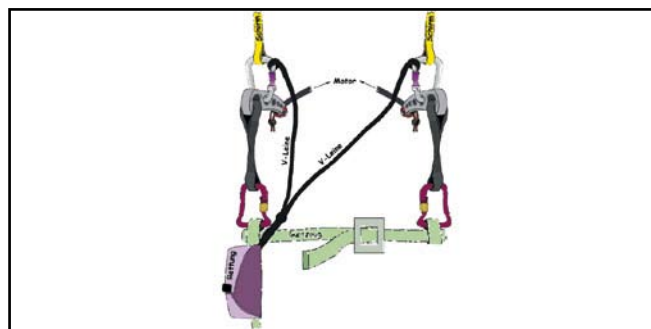

## HARNESS

# SOLO MANUAL

## HOW TO FASTEN THE HARNESS WINGMAN CB

Attach the harness with the velcro on the frame.



This picture show's the attached harness.



At next insert the cb bars into the frame ...



... and secure with the quickpins.



**WINGMAN CB**

**SOLO**  
MANUAL

The lateral and adjustable belt's from the harness goes outside the cb bar's.



The rear pilotsuspension must fixed in the metal-eyelet.



The rear pilotsuspension is adjustable. For basic position pull the loop until the carabiner. Heavy pilots should open and light weight pilots should close the belt.



Here you must fix the carringsstraps from harness to the frame.



**WINGMAN CB**

**SOLO**  
**MANUAL**

**FRESH BREEZE**  
POWERED PARAGLIDER



The glider should be fixed into this carabiner.



**WINGMAN CB**

# SOLO

## MANUAL



New features at the Wingman Cbi (integrated rescue)



At the Wingman Cbi the rescue is intergated.  
The neoprene outer container  
holds the rescue system,  
which is fitted with zipper onto the wingman.  
The V cord is runs behind the Pilot  
At the Wingman Cbi the rescue is intergated.



As you can see the Vcord runs  
around the pilot from behind.

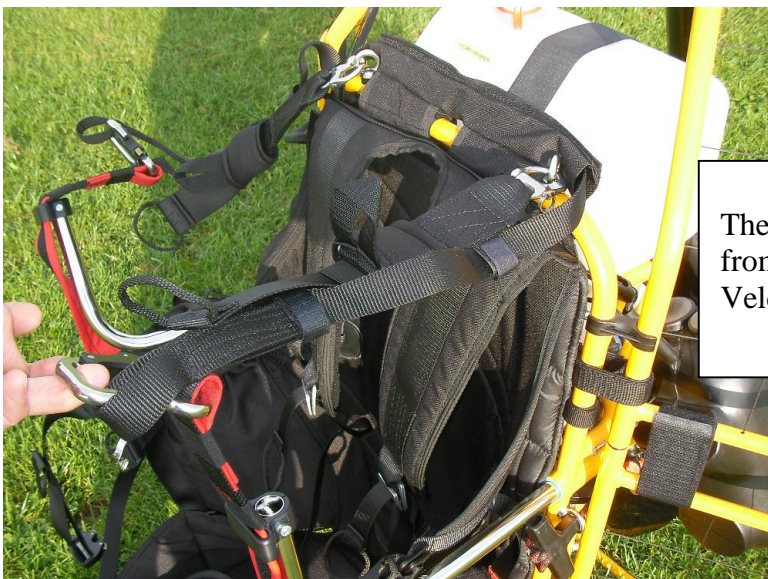

The V cord is led to the carabines  
from behind and fixed with the  
Velcro loops.



The carrying belts go through the back of the wingman.

Wingman CBi

*WINGMAN CBi*

# *MONSTER*

## *HANDBUCH*

***THE FOLLOWING POINTS SHOULD BE CARRIED OUT BEFORE EVERY START!***

01. CHECK ALL PARTS FOR TIGHTNESS, CHECK ALL FASTENERS!
02. VISUAL INSPECTION OF CAGE AND FRAME FOR FRACTURES!
03. PROPELLER HUB WITHOUT CLEARANCE?
04. EXHAUST SPRINGS OK?
05. EXAMINATION OF EXHAUST RUBBER ELEMENTS!
06. PETROL FILTER NOT SOILED?
07. MOTOR, CARBURETTOR AND TANK LEAK-PROOF?
08. SUFFICIENT SUPPLY OF PETROL?
09. PILOT SUSPENSION UNDAMAGED?
10. CANOPY UNDAMAGED?
11. GAS LEVER POSITION?
12. TRAVELLING LOCK RELEASED?
13. FUEL TAP OPEN?
14. VENTILATED TANK LID ON TANK?
15. PROPELLER CLEAR – START MOTOR!
16. CARRY OUT A TEST AT FULL THROTTLE!
17. TEST THE OFF-SWITCH FUNCTION
18. PILOT PROPERLY HOOKED IN?
19. WIND DIRECTION AND WIND FORCE?
20. FUEL TANK IS FIXED AND THE GAP BETWEEN EXHAUST-FUEL TANK ASSURED
21. TAKE-OFF STRETCH CLEAR?

***EVERYTHING O.K.? CLEAR FOR TAKE-OFF!***



***PREFLIGHT CHECK***

***SOLO  
MANUAL***



## ***CHECK BEFORE EACH FLIGHT***

- CAGE SECURED ON THE FRAME
- CAGE IN GOOD SHAPE
- PROPELLER-CLEARANCE
- PROPELLER WITHOUT FREE SPACE
- PROPELLER WITHOUT DAMAGE
- BELT O.K.
- TENSION O.K.
- KILLSWITCH O.K.
- FUEL MIN.98 OCTANE OR HIGHER
- FUEL TANK LEAKY
- PILOT SUSPENSION AND STRAP WITHOUT STRESSMARKS
- SPARKING PLUG AND WIRE WELL FIXED
- TANK-LID WITH SMALL HOLE ON THE TANK
- PROOF GLIDER, LINES AND RISER FOR STRESSMARKS OR DAMAGE´S.
- INTAKESILENCER AND IT´S FIRMNESS
- FULL RPM MIN 5900 1/MIN
- PROOF ALL RUBBERJOINTS

## ***CHECK ALL 10 HOURS***

- FUEL FILTER
- CLEAN THE CARBCHAMBER
- BELT
- EXHAUST INCL. THE SELAINGRINGS AND THE SCREWS.
- ALL CONNECTION FROM THE WIRES
- CHECK ALL 10 HOURS
- REPLACE THE BELT
- METAL-WIRE FROM THROTTLE
- REPLACE THE SPARKING PLUG AND THE CONNECTOR
- REPLACE ALL RUBBERJOINT FROM EXHAUSTSYSTEM
- REPLACE THE SEALINGRINGS AND THE SCREWS
- CHECK ALL SCREWS
- PROOF CARRINGSTRAPS FOR PRACTICAL
- LEAKY FROM WHOLE SYSTEM

## ***CHECKLIST***

# ***SOLO*** ***MANUAL***



## ***CHECK ALL 50 HOURS***

- PROPELLERBALANCE
- CHANGE NEEDLE AND NEEDLEJET
- REPLACE STARTERFINGER
- REPLACE INTAKETUBE

## ***CHECK ALL 100 HOURS***

- CLEANING THE DECOMPRESSIONHOLE INSIDE THE CYLINDER
- PISTONRINGS
- REPLACE CARABINER FROM PILOTSUSPENSION
- REPLACE CARB-SLIDER
- REPLACE BEARING FROM PROPELLERHUB
- CHECK BEARINGS FROM CRANKSHAFT

## ***CHECK ALL 300 HOURS***

- THE ENGINE AND HIS COMPONENTS SHOULD SEND TO THE MANUFACTURING FOR GENERAL MAINTENANCE

## ***PARAGLIDER***

THE GLIDER SHOULD BE CHECKED ALL 2 YEARS.SEND TO THE MANUFACTURER

## ***MOTOR***

THE ENGINE SHOULD BE CHECKED EACH YEAR ALIKE HOW MUCH HOURS IT'S USED



**WITHOUT THESE CHECK'S NO WARRENTY OR OTHER CLAIMS!**



**PLEASE USE ONLY FRESH BREEZE GENUINE SPARPARTS.THIS WILL TAKEN POSSESSION ALL SAFETY AND STIFFNESS WHICH IS REQUIERED FROM DULV.**



**Unexperienced pilot's should have minimum 70 kg (154 lbs).  
Otherwise you risk a stall or twist in while of full throttle**

## ***CHECKLIST***

# ***SOLO*** ***MANUAL***



***BE SURE TO FOLLOW THIS SAFETY ADVICE EVERY TIME YOU USE FRESH BREEZE MOTORS !***

- USE YOUR ENGINE CAREFULLY. DISREGARDING ANY SAFETY ADVICES AND INCAUTIOUS BEHAVIOUR MAY LEAD TO SERIOUS INJURIES.
- NEVER COME CLOSE OR GRAP INTO THE SPINNING PROPELLER. HIGH RISK OF SERIOUS INJURIES.
- THE ENGINE MAY NOT BE STARTED WHEN IT IS STANDING ON THE GROUND. HIGH RISK OF SERIOUS INJURIES.
- NEVER TOUCH HOT PARTS (ENGINE, EXHAUST). HIGH RISK OF BURNING.

***SAFETY ADVICE***

***SOLO***  
***MANUAL***

